

CAMON[®]

LANDSCAPING MACHINERY

CAMON SG30 Stump Grinder

ORIGINAL INSTRUCTION MANUAL



Manufactured by Tracmaster Ltd

**Before commissioning the machine, read operating instructions
and observe warning and safety instructions.**

Manufacturer Details

Tracmaster Ltd
Units 6-7 Winterpick Business Park
Hurstpierpoint Road
Wineham
Henfield
BN5 9BJ
UNITED KINGDOM
Tel: +44 (0)1444 247689
www.tracmaster.co.uk
info@tracmaster.co.uk

Machine Details

Model: CAMON SG30 Stump Grinder

Serial No:

A	0	8	-	1	1	1	1	1
---	---	---	---	---	---	---	---	---

Engine Serial No:

G	A	A	A	A	-	1	1	1	1	1	1	1
---	---	---	---	---	---	---	---	---	---	---	---	---

Purchase Date:

D	D	-	M	M	-	Y	Y	Y	Y
---	---	---	---	---	---	---	---	---	---

Supplier:

Table of Contents

1.0	Introduction	2
1.1	Welcome	2
1.2	About This Manual	2
2.0	What the Machine is Designed For	3
2.1	Applications	3
3.0	Specifications	4
4.0	Unpacking and Assembly	5
4.1	Major Components Diagram	5
4.2	Unpacking Instructions	5
5.0	Safety Instructions – Pre-Operation	7
5.1	Basic Safety Instructions	7
5.2	Main Components and Operating Elements	7
5.3	Engine and Drive	7
5.4	Operating Lever	7
5.5	Throttle Lever	7
5.6	Choke Lever	8
5.7	Rotor Disc and Teeth	8
5.8	Commissioning	8
5.9	General Safety Instructions	8
5.10	Engine Specific Safety Instructions	9
5.11	Machine Safety Sticker Explanations	9
6.0	Safety Instructions Starting and Operating	11
6.1	Before Starting the Engine	11
6.2	To Start the Engine	12
6.3	To Stop the Engine	13
6.4	Safety Equipment	13
6.5	Operation - Removing Stumps	13
6.6	Procedure for Cutting the Stump	14
6.7	Procedure for Unexpected Shut Down	15
6.8	Residual Risks of the SG30 Stump Grinder	15
7.0	Maintenance	16
7.1	Schedule	16
7.2	Basic Maintenance	16
7.3	Advanced Maintenance	16
7.3.1	Rotating Teeth	16
7.3.2	Replacing Teeth	17
7.3.3	Changing the Teeth Holder	17
7.4	Engine	18
7.4.1	Check Engine Oil Level	18
7.4.2	Change Engine Oil	18
7.4.3	Air Filter	19
7.4.4	Spark Plug	19
7.5	Cleaning	19
7.6	Troubleshooting	20
7.6.1	Machine	20
7.6.2	Engine	20
7.6.3	Lubricants	20
8.0	Transportation, Storage and Handling	21
8.1	Transportation	21
8.2	Storage	21
8.3	Handling	21
9.0	Spare Parts	22
10.0	Service Record	23
11.0	EC Declaration of Conformity	24
12.0	Warranty Information	25

1.0 Introduction

1.1 Welcome

Welcome to Tracmaster and thank you for choosing CAMON.

We are confident that you will be more than happy with your machine.

Your machine is covered by a comprehensive warranty. However, the lifespan of your CAMON machine depends on a number of factors. It is important that you read this manual carefully and follow the instructions regarding operation, maintenance, and care.

1.2 About This Manual

It is crucial that you read this manual carefully and understand it. Reading and understanding this manual should prevent you from operating the SG30 incorrectly and so extend the life of the machine.

This manual also contains important safety information about your machine. You must observe all safety instructions at all times. CAMON machines are often updated and improved so models may vary due to differences in specifications.

Any illustrations, descriptions, specifications, and technical data in this manual is correct at the time of printing.

For any questions relating to this manual please contact us.

During office hours (UK) we can be contacted on:

Phone: +44 (0)1444 247689

Email: info@tracmaster.co.uk

Website: www.tracmaster.co.uk



2.0 What the Machine is Designed For

2.1 Applications

The CAMON SG30 Stump Grinder has been designed by Tracmaster for removing tree stumps from above and below the surface of the ground.

The benefit of removing a tree stump is that it allows the landscape to be redesigned without the stump.

The teeth of the CAMON SG30 Grinder are designed to grind TREE STUMPS ONLY - they are NOT designed to make contact with solid ground, tarmac, concrete, paving etc, at any point during operation.

The machine will be damaged should the teeth continuously come into contact with solid ground, tarmac, concrete, paving etc.

DO NOT use the CAMON SG30 Grinder for cutting grass or digging the ground. These operations will result in damage to the machine.

DO NOT use the Stump Grinder if there is a likelihood of high temperatures or poor weather conditions.

3.0 Specifications

ENGINE	
Engine Manufacturer	Honda
Engine Model	GX360
Engine Type	4-stroke OHV, single cylinder
Net Engine Power	8.7kW (11.7hp) @ 3600rpm
Engine Shaft Size	1" straight
Spark Plug	BPR6ES (NGK) / W20EPR-U (DENSO)
Spark Plug Gap	0.70 - 0.80mm
Engine Ignition Type	Recoil
Cold Start System	Choke
Fuel Tank Capacity	6.1 litres
Fuel Type	Unleaded
Fuel Consumption	3.5 litres per hour @ 3600rpm
Air Filter	Paper
Rated Engine Speed	3600rpm
Working RPM	2800rpm
Engine Oil	10w/30 API SJ or equivalent
Engine Oil Capacity	1.1 litres
Dry Weight	30kg

The power rating of the engine indicated in this table is the net power output tested on a production engine for the engine model and measured in accordance with SAE J1349 at a specified rpm.

MACHINE	
Model	SG30
Disc Width	30cm
No of Teeth	8 Greenteeth®
Clutch Type	Centrifugal clutch
Working Height	45cm above ground to 30cm below ground
Discharge	Rear discharge
Handlebar	Foldable
Wheel Type	Pneumatic
Noise Level	104 dB(A)
Vibration Acceleration Value	3.1ms ²
Max Gradient for Operation on Slope	15 degrees
Weight	135kg
Dimensions (l x w x h)	190 x 63 x 126cm

4.0 Unpacking and Assembly

4.1 Major Components Diagram

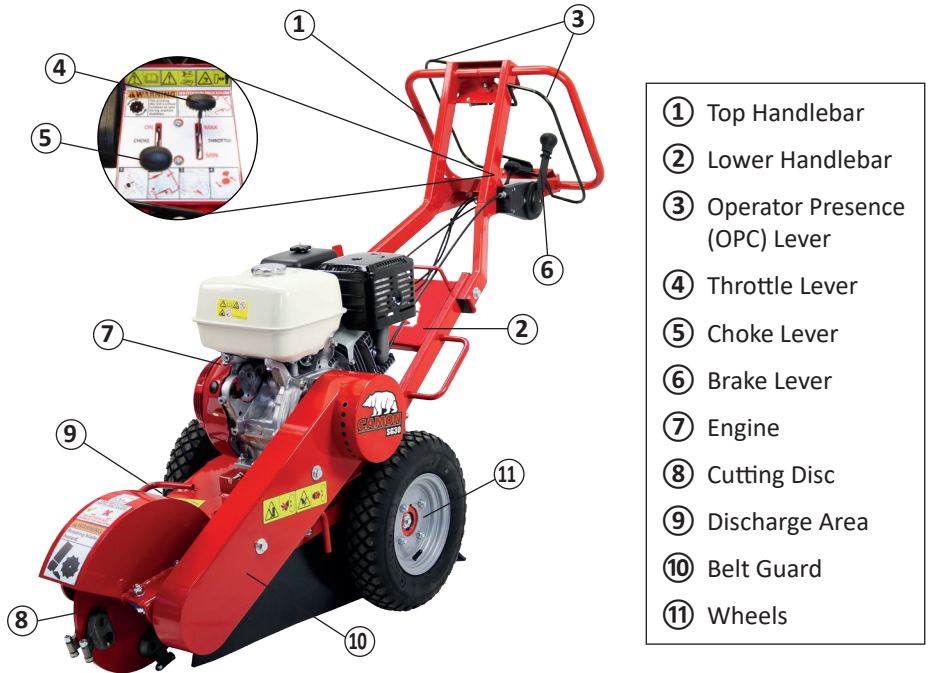

4.2 Unpacking Instructions

The SG30 Stump Grinder is usually delivered on a pallet, covered with pallet wrap, and secured with transport brackets which are fixed to the wheels.

Carefully remove any outer packaging.

Locate and remove any cable ties or straps that secure the Stump Grinder to the pallet.

Using 13mm spanners remove the bolts on the transport brackets. Once the brackets are removed, refit the washer and bolt back onto the wheels ensuring they are correctly tightened.

Push the machine forward safely and carefully off the pallet.

The handlebars will have been folded over the engine into a transport position.

To position the handlebars in their working position, remove and relocate the bolts at the bottom of the lower handlebar into the top position on the chassis (Fig. 1).



Loosen the large butterfly knob on the right hand side of the machine (Fig. 2) to allow the top handlebars to be rotated into the upright working position.

Re-tighten the butterfly knob to fix the top handlebars in the working position.

Dispose of the pallet and other packing material. Recycle where possible.

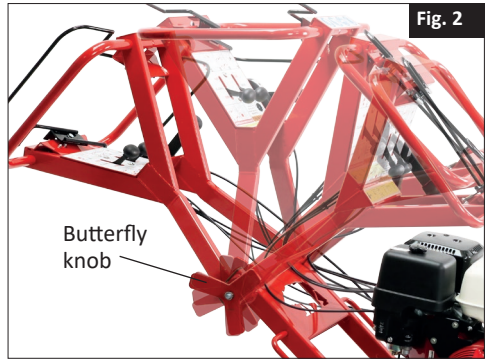

5.0 Safety Instructions – Pre-Operation

5.1 Basic Safety Instructions

Before starting the machine, read and understand these operating instructions.

5.2 Main Components and Operating Elements

Below is a description of the main components of the SG30 Stump Grinder and how they operate.

5.3 Engine and Drive

The Honda GX390 (Fig. 3) is a four stroke engine that runs on standard unleaded fuel.

The engine is air cooled and therefore it is important that the grille covering the recoil rope is kept clear from debris.

The engine air filter cleans the air sucked in by the engine. A clogged air filter will reduce performance.

The engine is fitted with a fuel on/off lever and a choke lever. Read the engine operating instructions to understand the operation of these levers.



5.4 Operating Lever

The engine of the SG30 Stump Grinder is controlled by the Operator Presence Control (OPC) lever (Fig. 4).

This lever turns the engine ON or OFF.

Squeezing the Operator Presence Control lever allows the engine to be started.

Letting go of the Operator Presence Control lever turns the engine off.

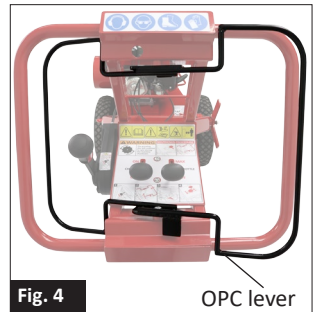

5.5 Throttle Lever

The throttle lever controls the engagement and speed of the rotor disc and teeth.

If the throttle lever is in the SLOW position the engine revolutions of the crank shaft is too low for the centrifugal clutch to engage and transfer power to the rotor shaft and cutting disc.

Positioning the throttle lever in the FAST position will engage the centrifugal clutch and the rotor shaft and cutting disc will rotate.



WARNING: MOVING THE THROTTLE FROM SLOW TO FAST MUST ALWAYS BE CARRIED OUT IN A CONTROLLED MANNER WITH THE OPERATOR UNDER COMPLETE CONTROL OF THE MACHINE.

5.6 Choke Lever

The choke lever is used to help start the engine when it is cold or being started for the first time.

Refer to the engine instructions for detailed instructions on the operation of the choke lever.

5.7 Rotor Disc and Teeth

The main rotor disc holds 8 teeth holders with each holder holding one carbide-tipped cutting tooth.

Each tooth can be turned through three positions in the holder, allowing the teeth to be used three times before they need changing.

5.8 Commissioning

Prior to operation it is necessary to check the engine oil level and, if required, add engine oil to the levels indicated in the table in section 6.2.

The engine fuel tank will not contain fuel so will need filling to the recommended level before use.

5.9 General Safety Instructions

Be aware of all the safety requirements for the machine.

Visually check the machine for operational safety, complete components and fixed guarding prior to each use.

Read and be aware of the warning and instruction signs located on the machinery.

Cordon off the work area to access from the general public.

Before starting work clear the area of any objects that may cause damage to the machine or operator.

Do not operate the machine if you are under the influence of alcohol or drugs. This equipment must only be operated by persons who are medically fit both physically and mentally.

Only work in good light and visibility.

Only operate the machine outdoors.

Wear the correct personal protection equipment (PPE) as instructed by this manual - gloves, steel toe capped boots or similar, eye protection and ear defenders.

Operator clothing should not be loose and footwear should offer good grip.

Know how to stop the machine in an emergency.

5.10 Engine Specific Safety Instructions



PETROL IS HIGHLY FLAMMABLE. ALWAYS STOP THE ENGINE AND ENSURE THE FUEL TAP IS TURNED OFF BEFORE REFUELING, OR WHEN TRANSPORTING, CLEANING, OR MAKING ADJUSTMENTS TO THE MACHINERY.

Do not smoke or use a naked flame when refueling.

Use only unleaded petrol from fuel containers designed for this purpose. Refuel outdoors only and replace the fuel tank cap securely.

Do not mix oil with the fuel.

Leave one inch of space in the fuel tank during refilling.

Clear up any petrol spillages immediately.

Always start the engine in the open air. Starting an engine within a confined space can lead to the inhalation of toxic substances.

Avoid contact with the engine during operation as it will become hot. Leave the engine to cool prior to contact and storage.

Never interfere with the control settings of the engine.

NEVER TILT THE MACHINE BACKWARDS WHEN CLEANING.

5.11 Machine Safety Sticker Explanations

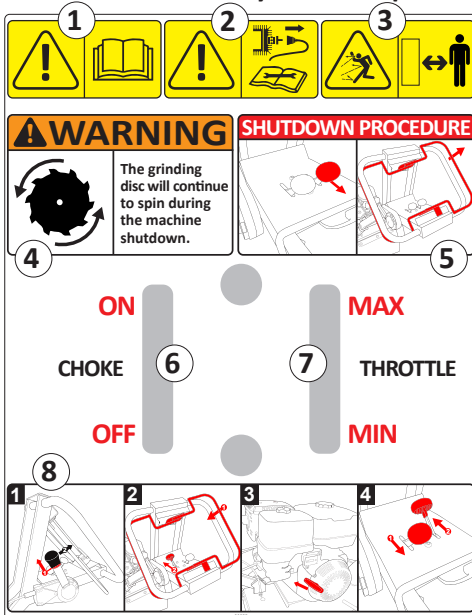

- ① Read operating instructions before use.
- ② Remove spark plug before servicing or performing maintenance.
- ③ Warning: Keep bystanders away.
- ④ Warning! Keep away from grinding disc after shutdown.
- ⑤ Shutdown procedure images.
- ⑥ Choke lever positions.
- ⑦ Throttle lever positions.
- ⑧ Starting procedure images.



Danger! Moving blades.
Do not remove safety guards whilst engine is running.
Keep hands and feet away.



Warning! Rotating blade.
Keep away.



Ensure safety guards are in place. Machine **MUST NOT** be operated without guards.



Maximum sound power level (LWA).
Ear protection must be worn when the machine is in use.



Important!
Ring ① **MUST** be lifted **BEFORE** moving lever ②.
DO NOT force the lever without lifing the ring first.

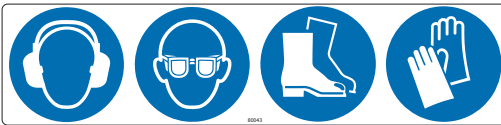

ALWAYS wear Personal Protective Equipment (PPE):
Ear defenders, eye and foot protection, safety gloves.

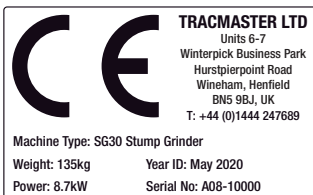

Machine identification label. Indicates compliance with European standards (CE mark). Includes unique serial number, machine weight, power output, and month and year of manufacture.

It is important that these stickers are in good condition, are legible, and are in the correct positions on the SG30 Stump Grinder.

Do not use the machine if any of these stickers are missing or damaged.

If any stickers are missing or damaged then they must be replaced. They can be obtained from the Spare Parts Department at Tracmaster Ltd.

6.0 Safety Instructions Starting and Operating

6.1 Before Starting the Engine

Review all of the safety decals that are placed on the machine for your safety and convenience. See Parts Diagram for aid in locating all decals on the machine.

Make sure that all shields, guards, and curtains are in place, and are in good condition prior to operating the machine.

Only responsible, properly instructed individuals should operate this machine. Inexperienced operators must always be carefully supervised.

Check cutting wheel for damage or missing teeth and replace as necessary.

Make sure that no-one is working on, underneath, or close to the machine before starting the engine or beginning to move the machine. Make sure that the area is free of personnel.

Check stumps to be removed for embedded nails, wire, metal fence posts, and other metallic objects, and for rocks or other buried impediments which may become dangerously thrown or cause unexpected machine movements when hit by the cutting wheel.

Ensure that everyone in the vicinity is aware of the **DANGER ZONE** associated with this machine – this is an 8m radius around the machine (see Fig. 5).

You and they must avoid the **DANGER ZONE** at all times when the machine is in operation.

The **SAFE ZONE** for the operator, subject to the operator wearing the appropriate safety equipment (PPE) as outlined in section 6.4, is indicated in Fig. 5.

Make no alterations or modifications to your SG30 Stump Grinder unless requested or recommended by Tracmaster Ltd.

Check with the local utilities for the locations of buried pipes and cables where applicable, before operating the machine.

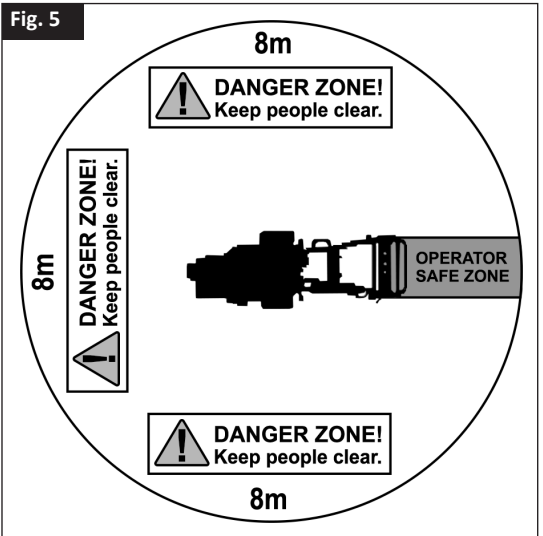

6.2 To Start the Engine

<p>Using the dipstick provided, check the engine oil level. Top up with SAE 10W/30 oil, API SJ or later, if the dipstick is clear of oil.</p>	
<p>Check the fuel level. Refill as necessary and as determined by the fuel tank type – see diagram.</p>	

Lock the left hand wheel by pulling brake lever fully back. **IMPORTANT:** Pull up ring ① before moving lever (Fig. 6).

Squeeze the Operator Presence Control (OPC) lever to turn the engine on (Fig. 7).

If engine is cold, move the choke lever to the “ON” position (Fig. 7).

Make sure throttle is in “MIN” position.

Raise the cutter wheel off the ground, approximately 4” to 5”, by pushing downward on the control handle. Hold it in that position.

! WARNING: THE NEXT STEP MAY CAUSE THE CUTTER WHEEL TO ROTATE. KEEP EVERYONE AWAY!

Pull the starter rope lightly until resistance is felt, then pull briskly (Fig. 8).

Move the choke lever to the “ON” position (Fig. 9).

! WARNING: THE NEXT STEP CAUSES THE CUTTER WHEEL TO ROTATE. KEEP EVERYONE AWAY!

Move the throttle to “MAX” position (Fig. 9).

If the engine is cold, allow the engine to idle (throttle set to “MIN” position) for a few minutes before cutting.

Once the engine is running, move the choke lever to the “OFF” position (Fig 9).

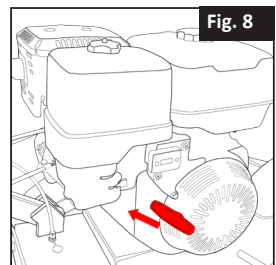
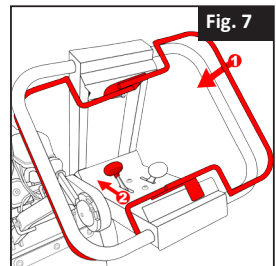
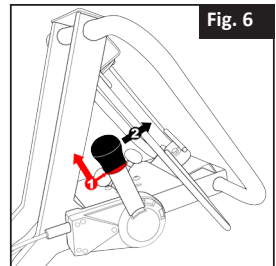

6.3 To Stop the Engine

Tilt the stump grinder to raise the teeth into the air.
 Move the throttle lever to the “MIN” position (Fig. 10).
 Release the operator presence lever (Fig. 11).
 Ensure the blades have stopped rotating prior to lowering or moving the machine.
 Turn the fuel tap lever to the “OFF” position.



WARNING: THE EXHAUST COVER MAY BE HOT – DO NOT TOUCH.

6.4 Safety Equipment

The SG30 Stump Grinder operator must be wearing suitable PPE including:

- Ear Defenders
- Gloves
- Protective Footwear
- Safety Glasses
- Forestry Helmet

6.5 Operation - Removing Stumps

Before grinding a stump the area must be cleared of any objects such as stones or metal that would damage the grinder or be picked up and thrown by the rotating blades. Remove all loose pieces of wood, stones, wire and other debris from the work area before beginning stump removal.



WARNING: REMOVE ALL HARD OBJECTS SUCH AS GRAVEL, ROCKS AND STONES TO REDUCE THE LIKELIHOOD OF THESE OBJECTS BEING THROWN BY THE STUMP GRINDER.

Wind direction should be considered, as it influences the direction in which dust and wood chips will be directed.

Never operate the machine in poor or low light as this would not allow the operator to see the stump and danger zone adequately enough for safe operation.

Always allow a cold engine time to warm up before cutting a stump.

Only the portion of cutting wheel within the 80° area shown in Fig. 12 should engage the stump.

Never undercut the stump or use the bottom of the cutting wheel for cutting purposes.

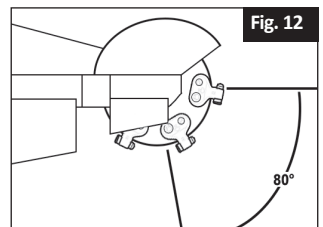
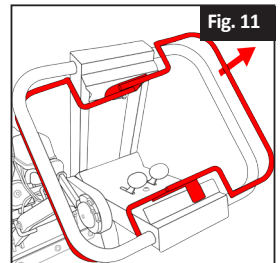
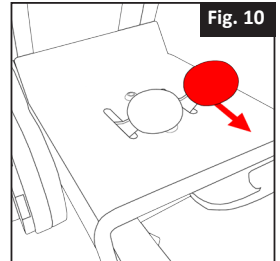
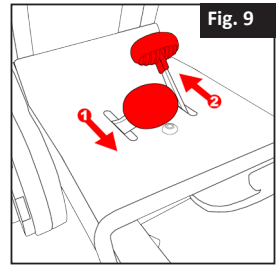

6.6 Procedure for Cutting the Stump

Position the SG30 Stump Grinder (Fig. 13).

Place the machine into position with the cutting wheel near the top edge of the stump.

Remove nearby roots first (Fig. 14).

Conduct the pre-starting inspection if not already done and start the engine as per the operating instructions above. Allow the engine to warm up for 30 seconds with the engine revs set to the "MIN" position prior to starting to remove the stump.

Lock the brake by pulling back the brake lever.

Make sure the throttle is set to "MAX". The cutter wheel is thus accelerated to cutting speed.

Swing the cutting wheel to one side, then lower it approximately 1" into the nearside roots that are buried at the foot of the stump.

Swing the cutting wheel across the roots, back and forth, lowering cutting wheel approximately 1" before each sweep, until the roots are sufficiently removed.

Raise the cutting wheel until the centre of the cutting wheel is just above the top of the stump.

Allow the cutter wheel to stop rotating, release the brake, and reposition the machine. Lock the brake again.

Remove the main part of the stump (Fig. 15).

Make sure the throttle is set to "MAX". The cutter wheel is thus accelerated to cutting speed.

Direct the cutter wheel against the stump, beginning with the nearside top corner of the stump, and steadily sweep it across the stump left and right, cutting away 1" of wood with each sweep.

Raise and lower the cutter wheel, between sweeps as needed, by lowering and raising the control handle.

Roll the machine forward and back by pushing and pulling on the control handle, between sweeps as needed, in order to progress into the stump. To do this, release the brake. Relock it when the machine has been repositioned, and continue cutting.

Shut off the engine by releasing the Operator Presence Control (OPC) lever.

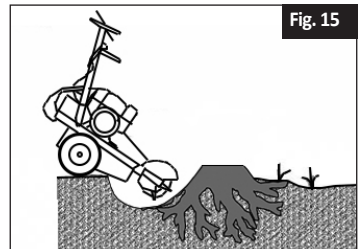
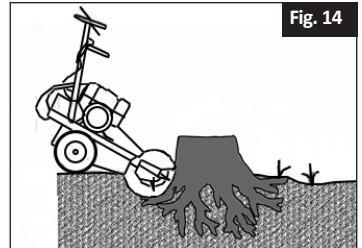
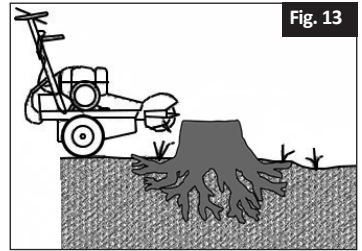

Helpful tips for operating the SG30 Stump Grinder

Use smooth, comfortable movements while operating.

When it is desired to cut smaller roots, it may be more effective to do so before, rather than after, cutting the stump.

Should the chip build-up become excessive when cutting, shut off the machine, wait for the cutting wheel to stop rotating, retract the machine from the stump, and rake away chips.

On larger stumps, when cutting from one side, eventually a tyre may tend to roll into the hole. This may be prevented by moving the machine to another side of the stump to continue removal, or by filling the hole with chips before continuing.



WARNING: NEVER USE THE STUMP GRINDER IN POOR OR LOW LIGHT.

6.7 Procedure for Unexpected Shut Down

Release the Operator Presence Control (OPC) lever.

Push down on the handlebars to raise the teeth into the air.

Ensure the rotor shaft and blades have stopped rotating prior to moving or lowering the machine.

6.8 Residual Risks of the SG30 Stump Grinder

The rotor shaft will continue to rotate for several seconds once the operating lever has been released. Ensure that the blades have stopped rotating prior to moving or tilting the machine.

The SG30 Stump Grinder is designed to be pushed by the operator both during transportation and operation. The SG30 Stump Grinder is fitted with a wheel brake on the left hand wheel that may be used to hold the machine on sloped areas.

7.0 Maintenance



IMPORTANT! BEFORE UNDERTAKING ANY MAINTENANCE ENSURE THAT THE ENGINE IS OFF AND THE FUEL TAP IS OFF.

7.1 Schedule

	Operation	Daily	Every Week	Every Month
Engine	Check engine oil level SAE 10W/30 API SJ or later See separate engine manual	X	X	
Machine	Check condition of teeth	X		
	Check belt condition		X	
	Check operating lever and cable		X	
	Check rotor shaft bearings			X
	Check all nuts and bolts are tight			X

7.2 Basic Maintenance

Check that all guards are fitted securely.

Ensure the cable connecting the operating lever to the engine is securely fastened at both ends and shows no sign of wear.

Check the pressure of pneumatic tyres and ensure that they do not show any indentations or significant wear and tear.

Ensure the wheels are held securely and the bolts that hold the wheels onto the axles are in place.

Check the wheels rotate smoothly and without hindrance.

Sparingly grease the cutter shaft bearings daily. Over-greasing the bearings will result in bearing failure.

7.3 Advanced Maintenance

We strongly recommend that an Authorised Representative is consulted prior to any major machine maintenance projects.

7.3.1 Rotating Teeth

Inspection Check:

A tooth that has become rounded on its leading edge (Fig. 16a) can be rotated to an unworn position facing forwards so that the SG30 Stump Grinder can continue to function properly (Fig. 16b).

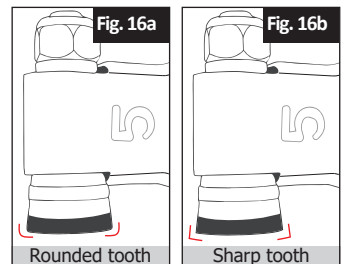

To Rotate Teeth:

To rotate a tooth, first loosen the locknut that holds the tooth in its holder on the tooth pocket.

Lift and rotate the tooth to the next indexed position so a sharp edge is facing forwards on the machine.

Re-tighten the nut to 27Nm to secure the tooth tightly in position.

7.3.2 Replacing Teeth**Inspection Check:**

Blades that have been worn so that they have become rounded must be changed for the SG30 Grinder to function properly (Fig. 16a).

To Replace Teeth:

Loosen and remove the locknut and spacer that hold the tooth in its holder on the tooth pocket.

Slide the worn tooth out of the tooth pocket.

Insert a new tooth with sharp carbide edges and re-fit the spacer. Ensure that the spacer is installed with the chamfered edge facing downwards so that it fits inside the tooth holder (Fig. 17).

Tighten the lock nut that holds the tooth in the tooth holder securely to 27Nm.

7.3.3 Changing the Teeth Holder**Inspection Check:**

Teeth holders that are damaged or which can move whilst the bolts are fully tightened must be replaced to ensure the safe retention of the teeth.

To Replace Teeth Holders:

There are two types of teeth holder on the cutting disc, a straight tooth holder and an angled tooth holder (Fig. 18). There are four of each type, eight in total, and they are fitted in pairs, one of each type either side of the cutting disc.

The holders must be fitted alternately, eg, the first pair would be a straight holder and an angled holder, then the second pair would be an angled holder and a straight holder, and so on.

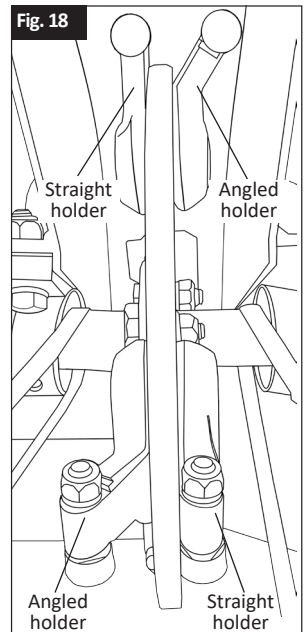
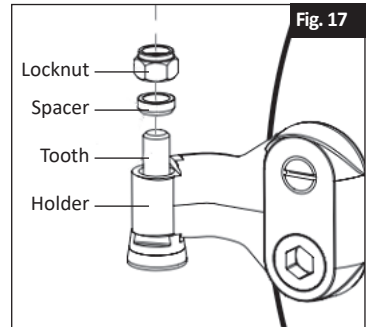

When changing the teeth holders it is essential that a similar type of holder is positioned in the same position as the holder that was removed.

! WARNING: INCORRECT FITTING OF TEETH HOLDERS ONTO THE ROTATING CUTTING DISC CAN SERIOUSLY AFFECT PERFORMANCE AND MAY DAMAGE YOUR MACHINE.

Loosen and remove the two bolts used to clamp the two teeth holders either side of the rotating cutting disc.

Replace the tooth holders with a similar tooth holder type and reposition and tighten the bolts to hold them in place (Fig. 19).

The tooth holders are reversible; each holder has one threaded hole and one counter-bored hole which allow the tooth holder bolts to feed into the wheel from opposite sides to ensure a strong secure setup.

The tooth holder bolts must be tightened to a torque setting of 244Nm if using antiseize (copper slip) or 325Nm dry.

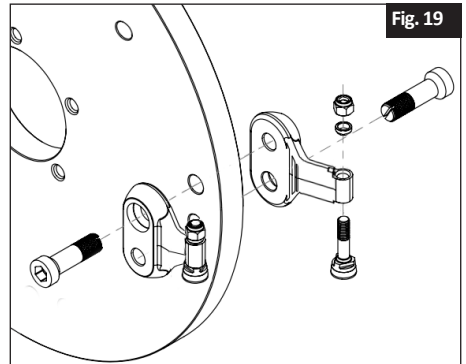

7.4 Engine

7.4.1 Check Engine Oil Level

This is to be checked prior to each use and every 8 hours during operation.

Check only when the engine is off and in a horizontal position.

Clean the oil filler plug and its surrounding parts.

Remove the oil filler plug. Clean the dipstick with a clean cloth and put the oil filler plug all the way back into the engine. Remove the oil filler plug and check the oil level.

Refill the oil if indicator shows more is required. For the Honda GX160 the recommended oil is SAE 10W/30 API SJ or equivalent.

7.4.2 Change Engine Oil

Refer to the engine manufacturer's manual for location of components and more detailed assistance.

Do not change the oil if the engine is hot.

The first oil change is after 50 hours of work.

Subsequent oil changes should be made after each 100 hours of work.

At extreme temperatures or conditions change the oil after every 50 hours.

Open the drain plug on the engine and the filling plug and drain the oil into a suitable container or use a suction pump to remove oil through filler neck.

Ensure the waste oil is disposed of properly.

Re-fit the drain plug and tighten.

Fill fresh engine oil through the oil filling opening. Use a funnel or similar device for ease of filling.

Replace the oil filler plug and tighten.

7.4.3 Air Filter

Inspection Check:

Remove the air cleaner cover and inspect the filter elements.

Cleaning:

See Fig. 20 containing information provided by Honda.

Cleaning Dual-Filter Element Types

1. Remove the wing nut from the air cleaner cover, and remove the cover.
2. Remove the wing nut from the air filter, and remove the filter.
3. Remove the foam filter from the paper filter.
4. Inspect both air filter elements and replace them if they are damaged. Always replace the paper air filter element at the scheduled interval.

7.4.4 Spark Plug

Clean and replace.

7.5 Cleaning

After cleaning, particularly if a pressure washer has been used, ensure any lubrication points are re-lubricated.

Clean the engine with a cloth only. Avoid spraying the engine with jets of water as this may leak into the fuel and ignition systems.

7.6 Troubleshooting

7.6.1 Machine

Have all serious malfunctions on the machine and engine repaired by an authorised Tracmaster or Honda agent.

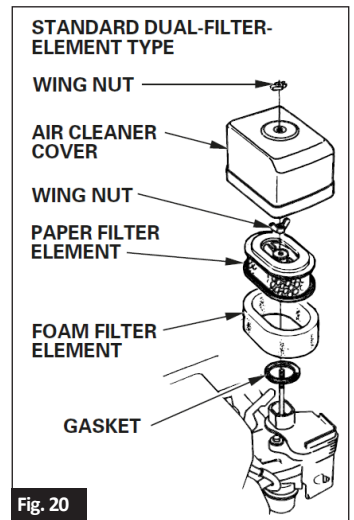

Problem	Possible Cause	Remedy
No drive to rotor disc.	Broken belt.	Replace belt.
	Damaged centrifugal clutch.	Replace clutch.
Poor performance.	Teeth are worn out.	Replace teeth.
	Teeth have become rounded on the bottom edge.	Turn teeth round or replace teeth.

7.6.2 Engine

Problem	Possible Cause	Remedy
Engine does not start.	Spark plug connector not connected.	Connect spark plug connector.
	Choke lever is not actuated.	Actuate choke lever.
	Fuel tank empty.	Fill fuel tank.
	Fuel line clogged.	Clean fuel line.
	Defective spark plug.	Clean or replace spark plug.
	Engine has too much fuel.	Dry and adjust spark plug and start engine on full throttle.
Engine overheats.	Low engine oil.	Refill immediately.
	Impaired cooling.	Clean cooling fan grille.
	Air filter clogged.	Clean air filter.

7.6.3 Lubricants

Use engine oil SAE 10W/30 API SJ or equivalent, as specified by Honda.

8.0 Transportation, Storage and Handling

8.1 Transportation

Use ramps where possible to manoeuvre the SG30 Stump Grinder into a transportation vehicle.

The SG30 Stump Grinder must be fixed securely using straps and by placing chocks behind the wheels.

Always transport the SG30 Stump Grinder horizontally and not tilted at an angle.

Ensure that the fuel control lever on the engine is moved into the OFF position so fuel does not leak into the carburetor during transportation.

8.2 Storage

Always allow the engine to cool down prior to storage.

Always clean the machine and dry thoroughly prior to storage and ensure all lubrication points have been re-greased.

For periods of long storage, change the engine oil.

Either drain the fuel completely or fill the fuel tank and add fuel stabilizer.

Do not store the SG30 Stump Grinder in wet rooms, where fertiliser is stored, or in stables as heavy corrosion may occur.

Always store the machine in a horizontal position.

8.3 Handling

Do not attempt to lift the machine alone. At least 4 people is the minimum required.

Gloves must be worn when lifting the SG30 Stump Grinder.

Do not tilt the machine so that fuel can leak into the air filter of the engine.

When performing maintenance on the SG30 Stump Grinder when it is situated on a work bench, ensure that the machine is firmly held in position at all times.

Do not lift the machine solely by the engine at any point.

9.0 Spare Parts

The spare parts diagrams and part numbers for the CAMON SG30 Stump Grinder can be found on our website or by contacting our spare parts department.

Spare parts can be ordered via the following methods:

Website: www.tracmaster.co.uk

Phone: +44(0) 1444 247689

Email: spares@tracmaster.co.uk

Or via your local Authorised Dealer.

10.0 Service Record

To ensure your machine is kept in peak condition we recommend that your CAMON SG30 Stump Grinder is serviced at regular intervals.

Contact Tracmaster on 01444 247689 to find out who your local Authorised Tracmaster Dealer is, or check our Dealer Locator online at www.tracmaster.co.uk.

Company:		Company:	
Date:		Date:	
Company Stamp: <i>(or address & authorised signature)</i>	1	Company Stamp: <i>(or address & authorised signature)</i>	2
Company:		Company:	
Date:		Date:	
Company Stamp: <i>(or address & authorised signature)</i>	3	Company Stamp: <i>(or address & authorised signature)</i>	4
Company:		Company:	
Date:		Date:	
Company Stamp: <i>(or address & authorised signature)</i>	5	Company Stamp: <i>(or address & authorised signature)</i>	6

11.0 EC Declaration of Conformity



Tracmaster Ltd declares that the machinery stipulated below complies with all the relevant provisions of:

Machinery Directive 2006/42/EC

EMC Directive 2004/108/EC

and the National Laws and Regulations adopting these directives and other relevant directive.

Manufacturer: Tracmaster Ltd
Units 6-7 Winterpick Business Park
Hurstpierpoint Road
Wineham
Henfield
BN5 9BJ
UNITED KINGDOM

Machine Description: Stump Grinder

Type: CAMON SG30

Harmonised Standards applied (including parts of):

EN 13857:2008	Safety of machinery: Safety distance to prevent danger zones being reached by the upper and lower limbs.
EN 12100-1:2003	Safety of machinery: Basic Principles. Terminology. Methodology.
EN 12100-2:2003	Safety of machinery: Basic Principles. Technical Principles.

Responsible Person: Jody Symons

Position in Company: Technical Director

Address: Tracmaster Ltd, Units 6-7 Winterpick Business Park, Hurstpierpoint Road, Wineham, Henfield, BN5 9BJ

Date: April 2016

Signature: 

12.0 Warranty Information

The Warranty applies to any part of the machine, except the engine, which presents manufacturing or assembly defects in the opinion of Tracmaster Ltd.

The Warranty covers the original purchaser of the machine from the date of sale for the warranty period. The Warranty is non-transferable.

The warranty period begins the day the machine is delivered to the customer and is valid for the following periods:

- For domestic or private use: 3 years
- For commercial and hire use: 2 years

Tracmaster Ltd will replace or repair, at their discretion, free of charge, any such defective material providing the machine is returned to their workshops or an Authorised Tracmaster Dealer (contact us or see www.tracmaster.co.uk/apps/store-locator).

Should the owner of the machine wish to install the parts themselves then the labour involved will be at their cost and will not be reimbursed. Expenses arising from any subsequent failure of any part due to incorrect assembly by the owner of the machine shall be borne by the owner of the machine.

To validate warranty the Warranty Registration Card must be completed and returned, or complete the form online at www.tracmaster.co.uk/pages/warranty-registration-form.

The Warranty does not cover any transport costs, or direct or indirect losses owing to loss of use of the machine as a consequence of manufacturing defects or mechanical failure.

No Warranty shall be acknowledged in the following instances:

- The failure is caused by non-compliance of Tracmaster's directions for the correct use and operation of the machine.
- Seals and settings have been tampered with.
- Repair or modification has not authorised by Tracmaster Ltd.
- Routine maintenance, as advised in this manual, has not been undertaken.
- Incorrect fuels or lubricants have been used.
- Wear to consumable items such as blades, tines, belts, cables, tyres etc.
- Normal wear and tear.
- The failure is due to abuse / misuse / neglect.

For any issues relating to the engine please contact an authorised service centre for the engine. The engines are warranted according to the practices set by their respective manufacturers and distributors.

If an issue develops with the machine, within the warranty period, the problem must be verified by Tracmaster or an Authorised Tracmaster Dealer before any repair is undertaken.

Any other express or implied warranty is cancelled and substituted by this Warranty, whose clauses can be modified in writing only.

This Warranty provides specific legal rights and is in addition to any statutory rights. Your statutory rights are not affected by this Warranty.



CAMON SG30 Stump Grinder
Original Instruction Manual
Rev. 05/2025.A

© 2025 Tracmaster Ltd

MANUFACTURED BY



Tracmaster Ltd

Units 6-7 Winterpick Business Park | Hurstpierpoint Road | Wineham | Henfield | BN5 9BJ | UK
Tel: +44 (0)1444 247689 | www.tracmaster.co.uk | info@tracmaster.co.uk